

LADDER EXT. STANDARD MANHOLE

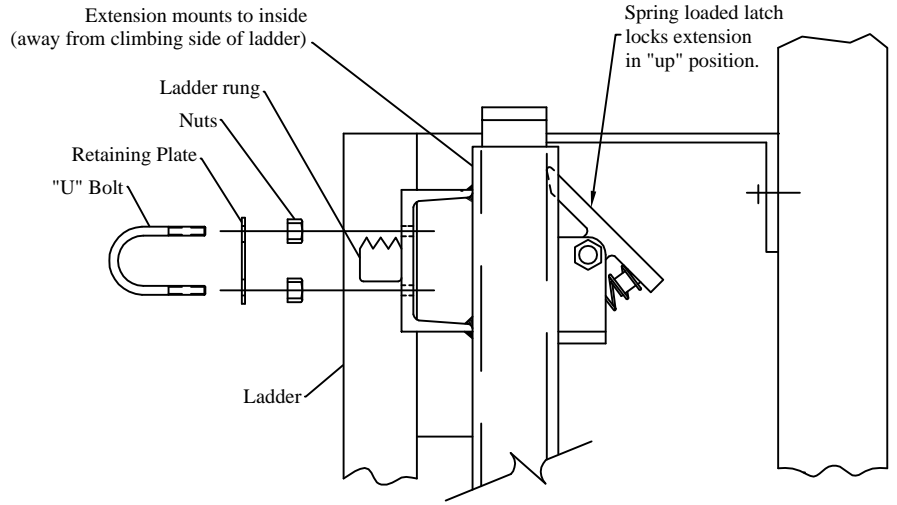

LADDER APPLICATION

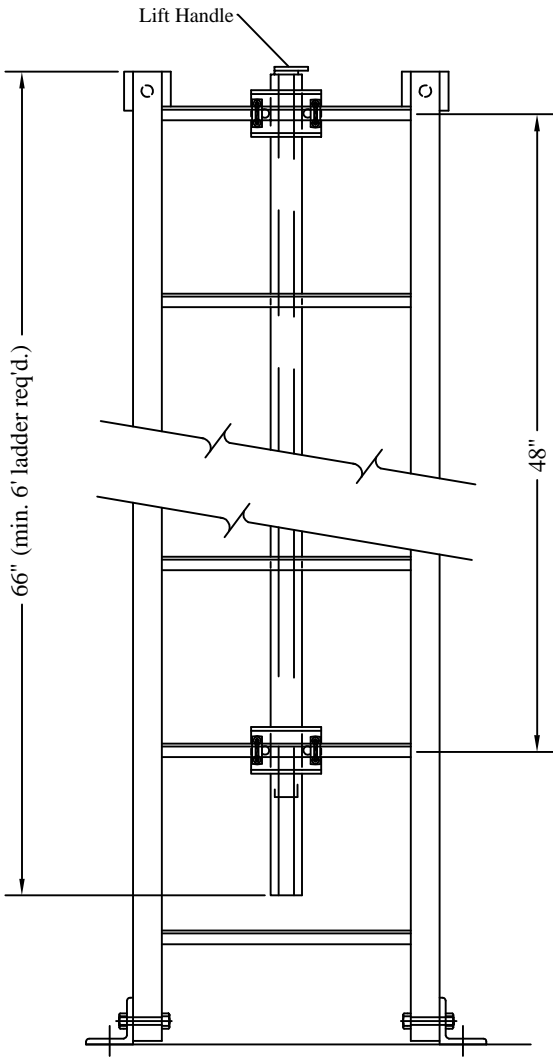
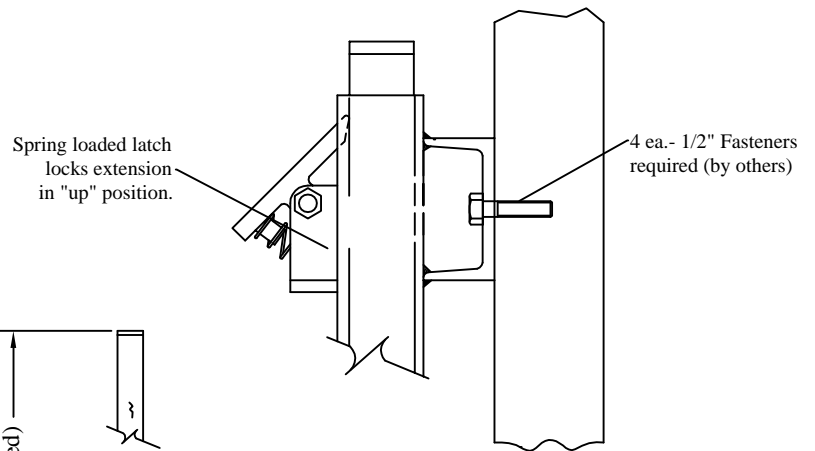

WALL APPLICATION

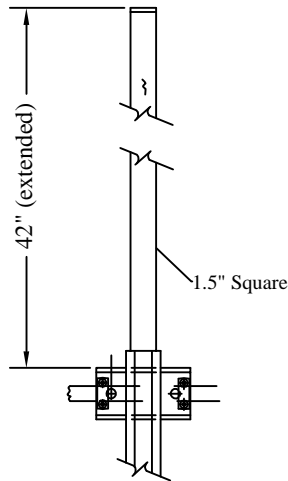
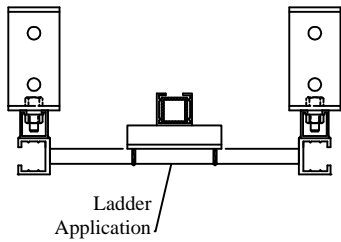

SPECIFICATIONS:

Ladder Handrail Extension Post shall be as manufactured by Pennsylvania Insert Corp., Spring City, PA. Extension shall be all aluminum and stainless steel. Post housing shall fasten to ladder rungs or wall with 316 S.S. fasteners. Extension shall telescope manually and automatically lock in the "up" position. Extension shall release when latch is disengaged. Manufacturer shall guarantee material and workmanship for a period of five years

AC MILLER
CONCRETE PRODUCTS, INC.
WWW.AC MILLER.COM

NPCA
CERTIFIED PLANT

31 E. BRIDGE ST.
SPRING CITY
PA. 19475

PHONE:
(610) 948-4600
FAX:
(610) 948-9750

RT.22 WEST
BLAIRSVILLE,
PA. 15717

PHONE:
(724) 459-5950
FAX:
(724) 459-9151

Precast Concrete
Ladder Extension

FILE NAME: WITH LADDER EXT

DATE: 8/20/03

DRAWN BY: BTH