

LADDER UP
STANDARD MANHOLE

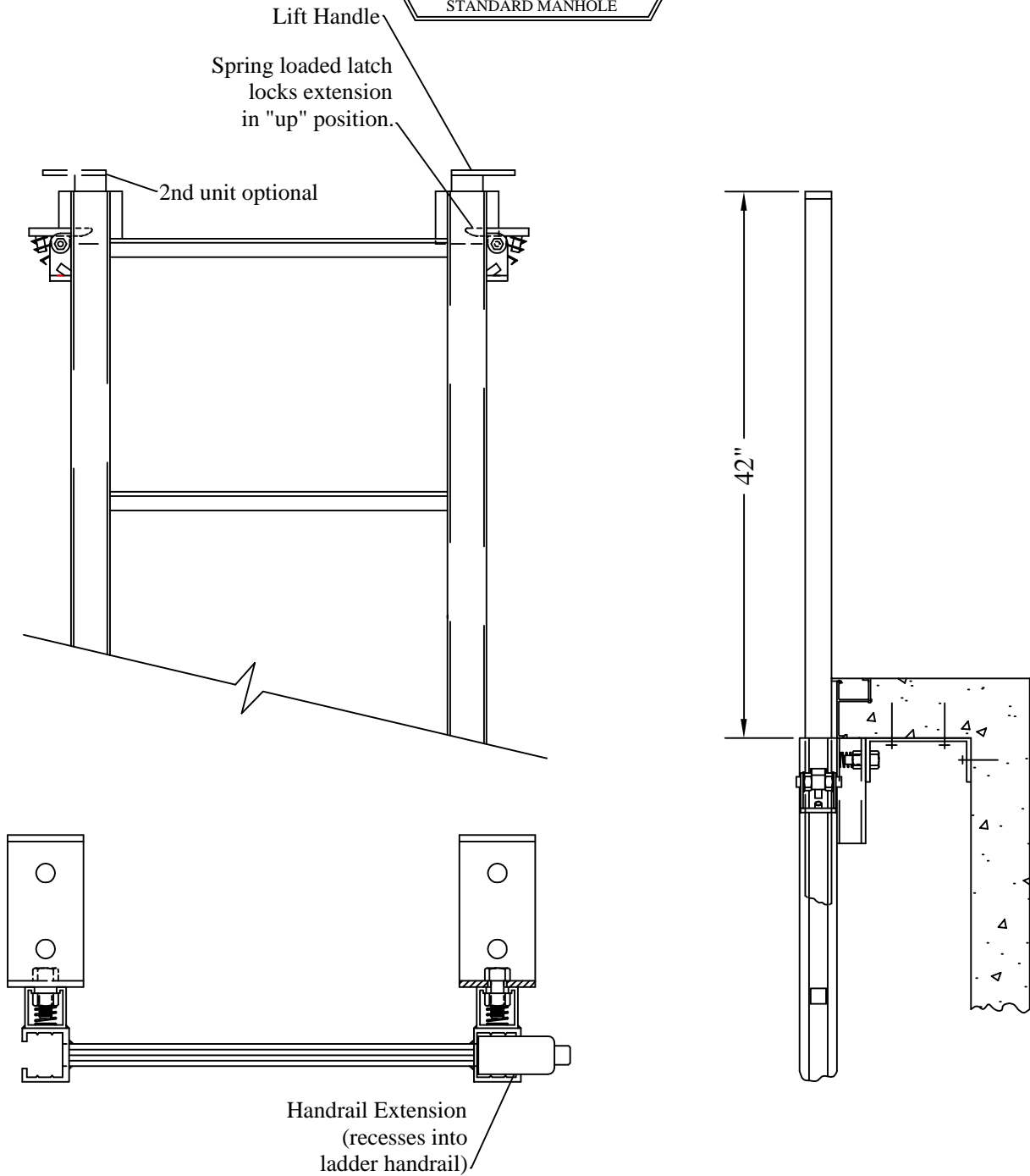

SPECIFICATIONS:

Integral Ladder Handrail Extension shall be as manufactured by Pennsylvania Insert Corp., Spring City, PA. Extension shall be all aluminum and stainless steel. The ladder rail shall function as the housing for the extension. The extension shall telescope manually and automatically lock in the "up" position. Extension shall release when latch is disengaged. Hardware shall be all stainless steel. Extension shall be mill finish. Manufacturer shall guarantee material and workmanship for a period of five years.

AC MILLER
CONCRETE PRODUCTS, INC.
WWW.AC MILLER.COM

31 E. BRIDGE ST.
SPRING CITY
PA. 19475

PHONE:
(610) 948-4600
FAX:
(610) 948-9750

RT.22 WEST
BLAIRSVILLE,
PA. 15717

PHONE:
(724) 459-5950
FAX:
(724) 459-9151

Precast Concrete
Ladder Up

FILE NAME: WITH LADDER UP

DATE: 8/20/03

DRAWN BY: BTH