

FRAME & COVER

ELECTRIC
POWER
SEWER
WATER
GAS

	24"	30"	36"
(A)	24	32"	38"
(B)	1-3/8"	1.5"	1.5"
(C)	22"	30"	34"
(E)	33-3/4"	38"	46"
(F)	4"	4"	6"

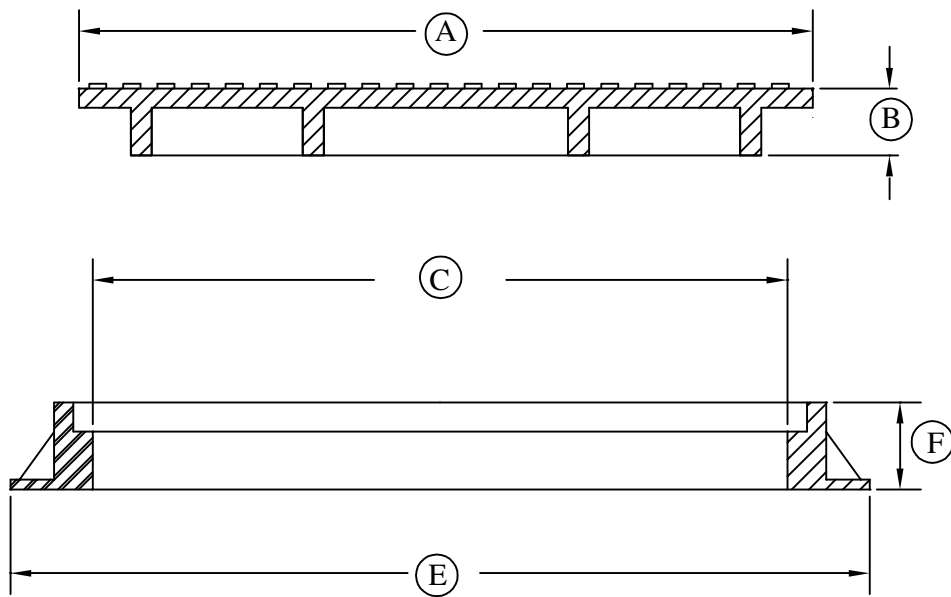
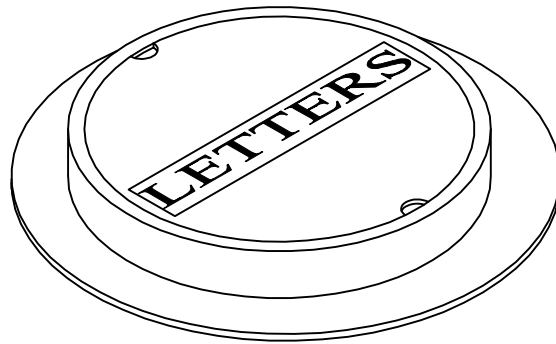

MATERIAL = ASTM A-48, CLASS 30
 DESIGNED FOR H-20-S16 HIGHWAY LOADING
 (2) CONCEALED PICKHOLES
 LETTERS 2" HIGH
 (1) COAT OF BLACK ASPHALTUM

AC MILLER
CONCRETE PRODUCTS, INC.
 WWW.AC MILLER.COM

31 E. BRIDGE ST.
 SPRING CITY
 PA. 19475

PHONE:
 (610) 948-4600
 FAX:
 (610) 948-9750

RT.22 WEST
 BLAIRSVILLE,
 PA. 15717

PHONE:
 (724) 459-5950
 FAX:
 (724) 459-9151

Precast Concrete
 Cast Iron Frame & Cover

FILE NAME: WITH 10 FRAMECOVER

DATE: 8/20/03

DRAWN BY: BTH