

POCKET
STANDARD MANHOLE

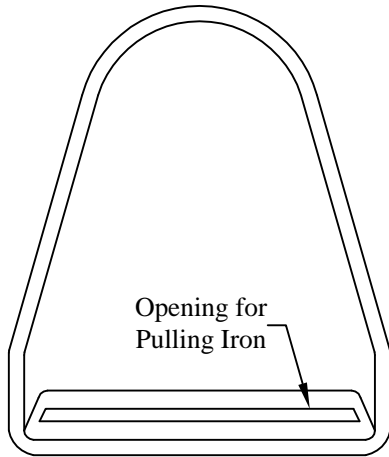

FRONT

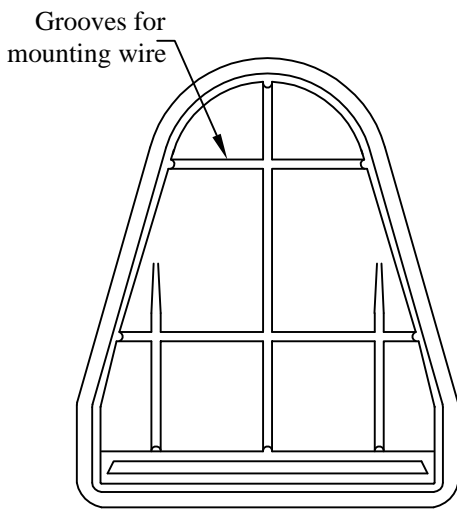
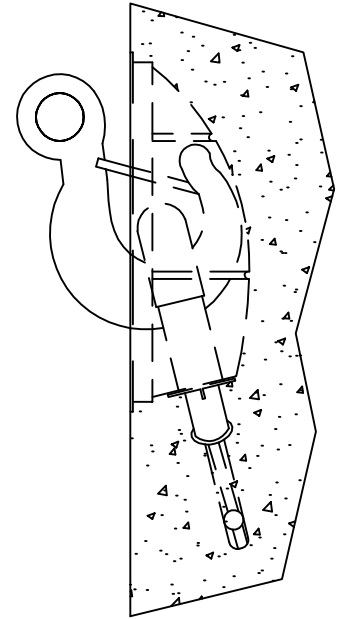

BACK

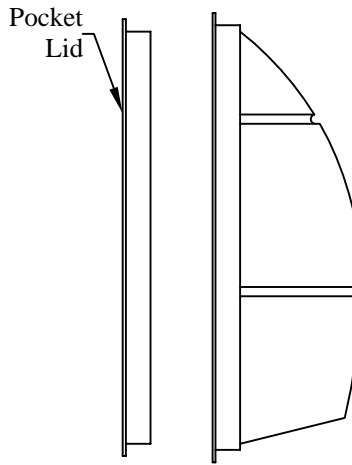

SIDE

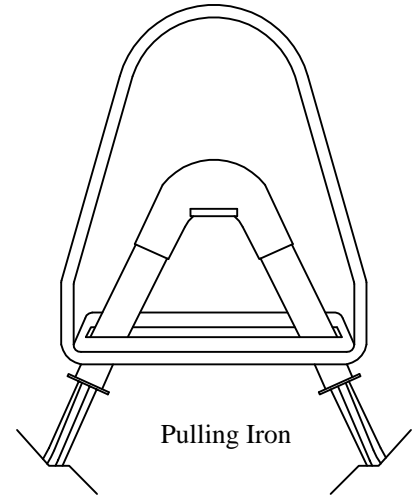

Pulling Iron

SPECIFICATIONS:

Pulling Iron Pocket and Pocket Lid shall be as manufactured by Pennsylvania Insert Corp., Spring City, PA. Pulling Iron Pocket and Pocket Lid shall be injection molded from high strength Polystyrene. Pocket shall be designed to cast Pulling Irons recessed in walls, ceilings or floors. Pocket shall feature grooves molded into its surface to facilitate mounting of part with wire. Pocket Lid shall fit into Pocket and shall be reusable. Opening in bottom of Pocket shall be sized to prevent concrete leakage when used with Pennsylvania Insert Pulling Irons.

AC MILLER
CONCRETE PRODUCTS, INC.
WWW.AC MILLER.COM

31 E. BRIDGE ST.
SPRING CITY
PA. 19475

PHONE:
(610) 948-4600
FAX:
(610) 948-9750

RT.22 WEST
BLAIRSVILLE,
PA. 15717

PHONE:
(724) 459-5950
FAX:
(724) 459-9151

Precast Concrete
Pocket Pulling Iron

FILE NAME: WITH PULLING POCKET

DATE: 8/20/03

DRAWN BY: BTH