

**SUMP DETAIL**  
STANDARD MANHOLE

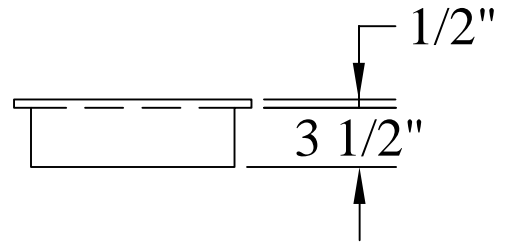

**SUMP RECESS DETAIL  
(OPTIONAL CAST IN SUMP)**

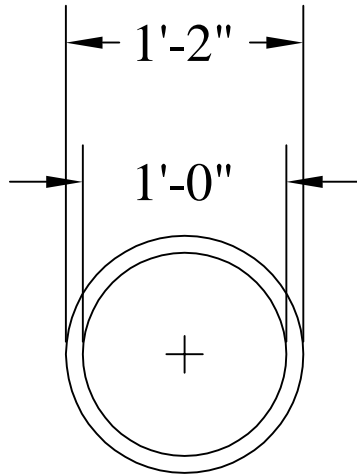
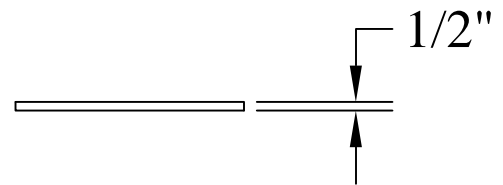
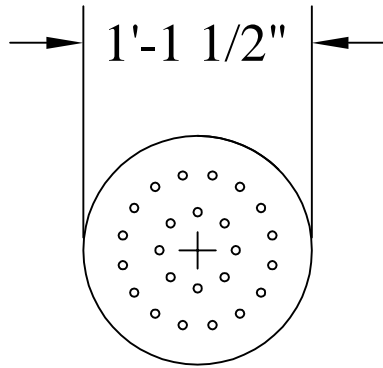

**OPTIONAL  
(PAI) SUMP LID**

\* PLEASE NOTE:  
ACM USES INSIDE DIMENSIONS TO  
DESCRIBE VAULT SIZE.

JOB: \_\_\_\_\_  
CUSTOMER: \_\_\_\_\_  
DRAWING \_\_\_ OF \_\_\_

LIVE LOAD: HS-20  
EARTH COVER: 0 to 2 ft.  
CONCRETE: 5000 psi AT 28 DAYS  
REBAR: GRADE 60, ASTM A615 SPEC'S  
PRECAST CONCRETE VAULT CONFORMS TO ASTM  
C890 AND C913 SPECIFICATIONS

**AC MILLER**  
CONCRETE PRODUCTS, INC.  
WWW.AC MILLER.COM

31 E. BRIDGE ST.  
SPRING CITY  
PA. 19475

PHONE:  
(610) 948-4600  
FAX:  
(610) 948-9750

RT.22 WEST  
BLAIRSVILLE,  
PA. 15717

PHONE:  
(724) 459-5950  
FAX:  
(724) 459-9151

Precast Concrete  
Sump Detail

FILE NAME: WITH SUMP

DATE: 8/20/03

DRAWN BY: BTH