

GREASE TRAP

STANDARD MANHOLE

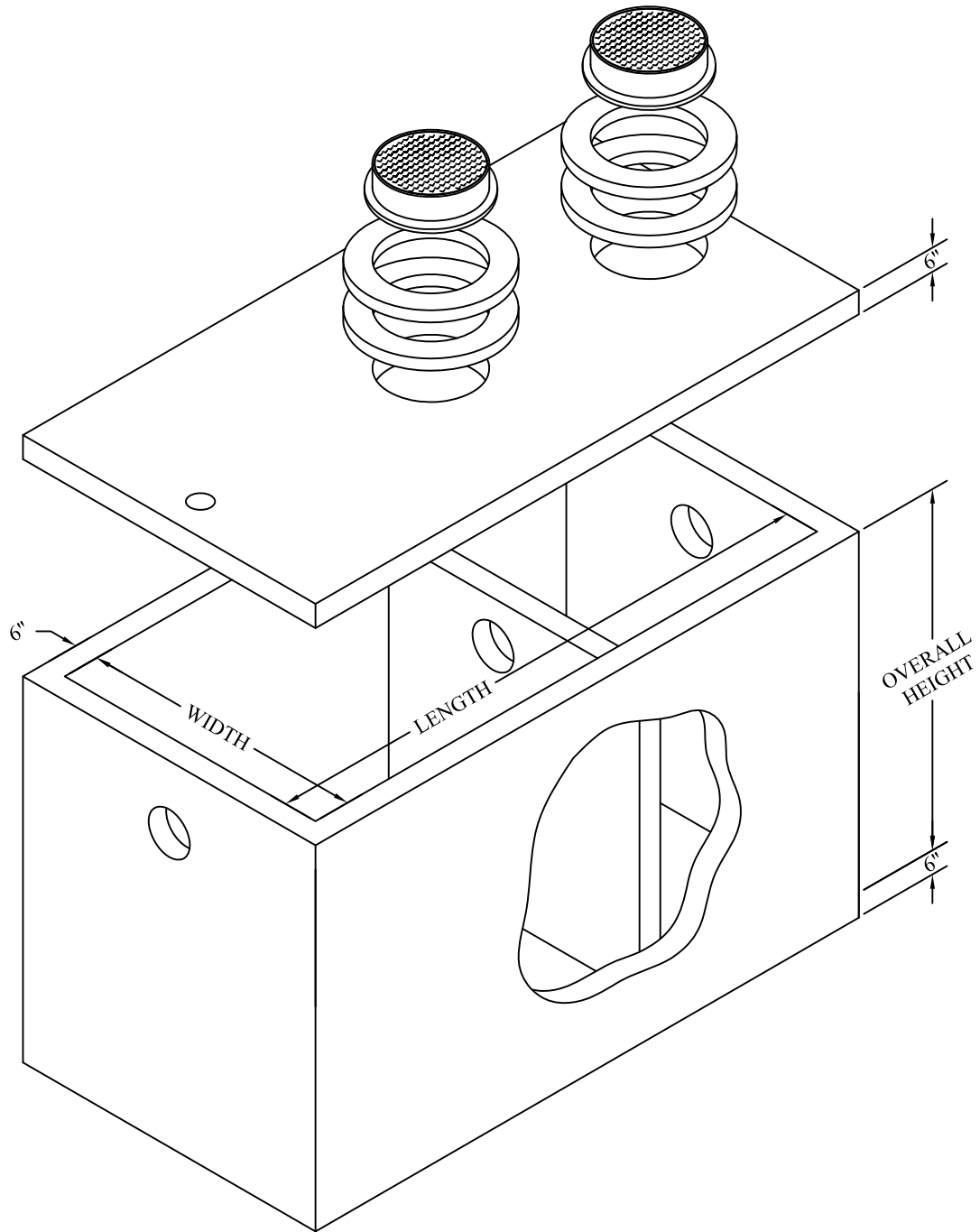

CAPACITY (GALLONS)	WIDTH	LENGTH	OVERALL HEIGHT
500	4'-0"	6'-0"	5'-6"
800	4'-0"	6'-0"	7'-6"
1000	6'-0"	6'-0"	6'-6"
1500	6'-0"	8'-0"	7'-0"
2500	6'-0"	12'-0"	7'-6"

AC MILLER
CONCRETE PRODUCTS, INC.

WWW.ACMILLER.COM



31 E. BRIDGE ST.
P.O. BOX 199
SPRING CITY
PA. 19475

9558 ROUTE 22
P.O. BOX 93
BLAIRSVILLE,
PA. 15717

PHONE:
(610) 948-4600
FAX:
(610) 948-9750

PHONE:
(724) 459-5950
FAX:
(724) 459-9151

Precast Concrete Grease Trap
with Solid Walls and Baffle Wall

FILE NAME: GREASE TRAP P1

DATE: 6/2/18

DRAWN BY: BTH