

SPECIFICATIONS	
RAIL TYPE	MID SECTION QTY.
<input type="checkbox"/> 100LB AREA RAIL / 5-1/2" BASE	
<input type="checkbox"/> 115LB AREA RAIL / 5-1/2" BASE	
<input type="checkbox"/> 132LB AREA RAIL / 6" BASE	
<input type="checkbox"/> 133LB AREA RAIL / 6" BASE	
<input type="checkbox"/> 136LB AREA RAIL / 6" BASE	

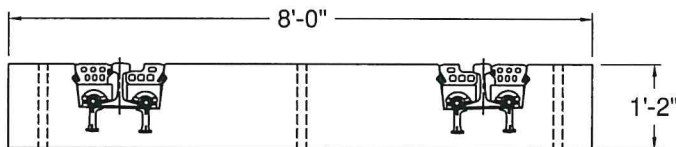
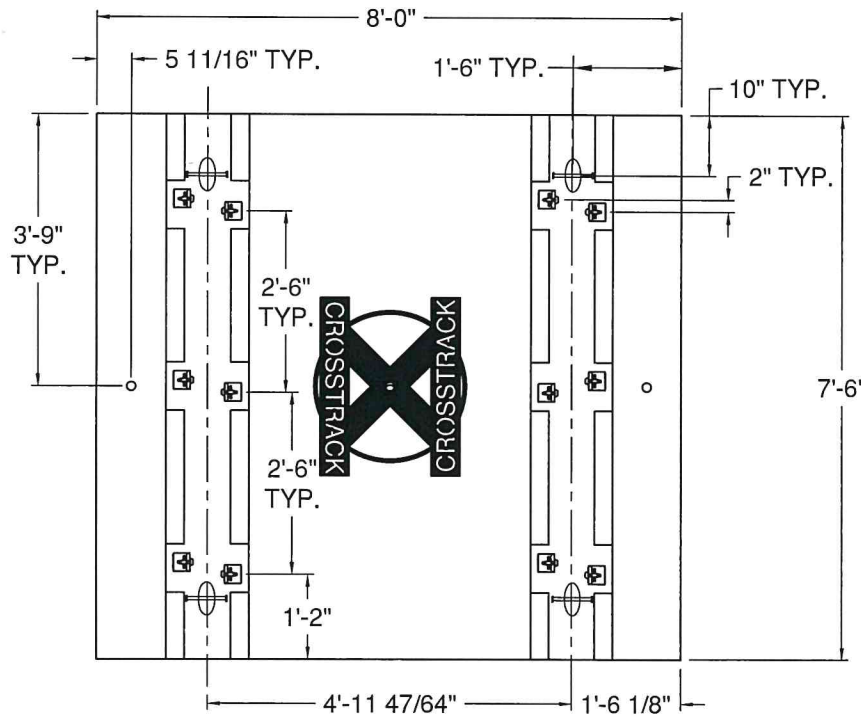

MATERIALS:

- DESIGN LOADING: COOPER E-80 WITH 60% IMPACT AND HS-25 WITH 30% IMPACT
- REBAR: ASTM 615, GRADE 60, PLAIN (OPTIONAL UPON REQUEST-EPOXY)
- CONCRETE: MINIMUM 28 DAY STRENGTH TO BE 6,000 PSI WITH BASF MASTERLIFE CI30 SERIES CORROSION-INHIBITING ADMIXTURE.
- EXPOSED SURFACE PENETRATING SEALER TO BE BASF MASTERPROTECT H200 SERIES
- SHOULDERS: PANDROL 6575, CAST DUCTILE
- CLIPS: PANDROL E2055, GALVANIZED
- INSULATORS: PANDROL 7400, THERMOPLASTIC/NYLON
- ABRASION STRIPS: 3/16" UHMW POLYETHYLENE
- RAIL FILLER: GROOVED RUBBER
- SEALANT: CONSEAL CS-102
- CAULK: SIKA-1A

FEATURES:

- CHAMFERED EDGES
- UTILITY LIFTING/HANDLING ANCHORS
- (3) 1-1/4" DIAMETER EPOXY JACKING PORTS
- SKID RESISTANT TINE FINISH ON TOP OF SLAB

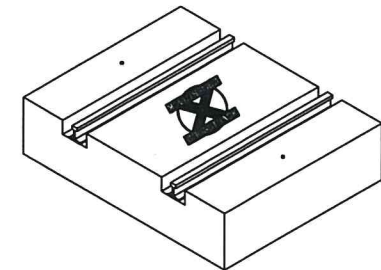

<p>CONCRETE PRODUCTS, INC. www.acmiller.com</p>	<p>CERTIFIED PLANT</p>
-----------------------------------------------------	------------------------

BLAIRSVILLE - 724-459-5950
 SPRING CITY - 610-948-4600

SIZE & DESCRIPTION:
8'-0" x 7'-6" RAILWAY CROSSING

DRAWN BY: BSV	DRAWING DATE: 10/1/2020
------------------	----------------------------

APPROVED FOR PRODUCTION BY: _____ DATE: _____

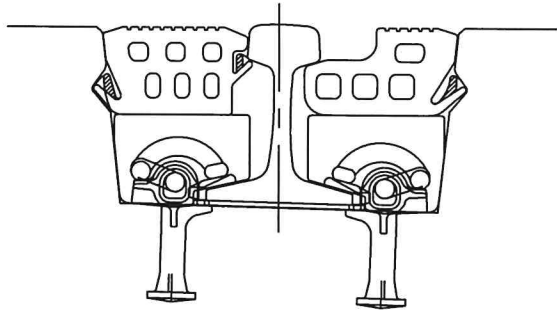

SPECIFICATIONS	
RAIL TYPE	END SECTION QTY.
<input type="checkbox"/> 100LB AREA RAIL / 5-1/2" BASE	
<input type="checkbox"/> 115LB AREA RAIL / 5-1/2" BASE	
<input type="checkbox"/> 132LB AREA RAIL / 6" BASE	
<input type="checkbox"/> 133LB AREA RAIL / 6" BASE	
<input type="checkbox"/> 136LB AREA RAIL / 6" BASE	

MATERIALS:

- DESIGN LOADING: COOPER E-80 WITH 60% IMPACT AND HS-25 WITH 30% IMPACT
- REBAR: ASTM 615, GRADE 60, PLAIN (OPTIONAL UPON REQUEST-EPOXY)
- CONCRETE: MINIMUM 28 DAY STRENGTH TO BE 6,000 PSI WITH BASF MASTERLIFE CI30 SERIES CORROSION-INHIBITING ADMIXTURE.
- EXPOSED SURFACE PENETRATING SEALER TO BE BASF MASTERPROTECT H200 SERIES
- SHOULDERS: PANDROL 6575, CAST DUCTILE
- CLIPS: PANDROL E2055, GALVANIZED
- INSULATORS: PANDROL 7400, THERMOPLASTIC/NYLON
- ABRASION STRIPS: 3/16" UHMW POLYETHYLENE
- RAIL FILLER: GROOVED RUBBER
- SEALANT: CONSEAL CS-102
- CAULK: SIKA-1A

FEATURES:

- CHAMFERED EDGES
- UTILITY LIFTING/HANDLING ANCHORS
- (3) 1-1/4" DIAMETER EPOXY JACKING PORTS
- SKID RESISTANT TIRE FINISH ON TOP OF SLAB

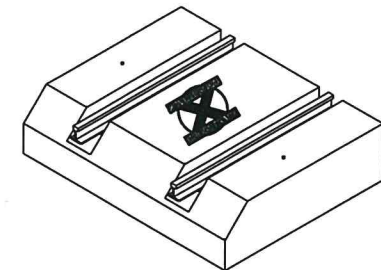
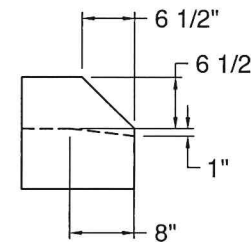
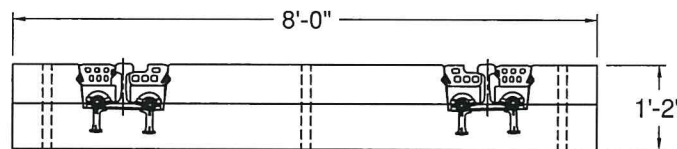
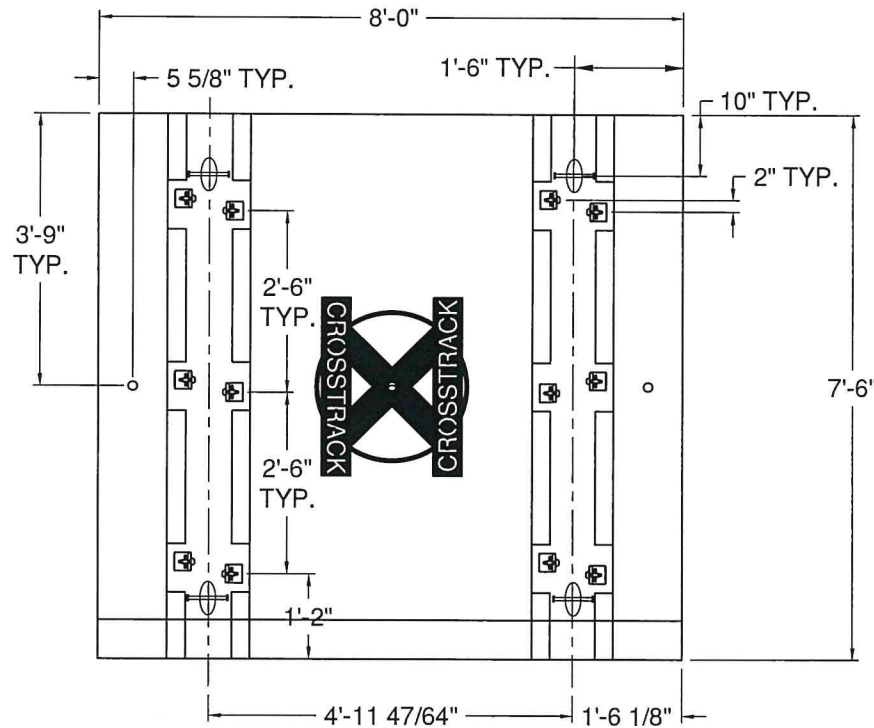

APPROVED FOR PRODUCTION BY: _____ DATE: _____

BLAIRSVILLE - 724-459-5950 SPRING CITY - 610-948-4600			
SIZE & DESCRIPTION: 8'-0" x 7'-6" RAILWAY CROSSING			
DRAWN BY: BSV		DRAWING DATE: 10/1/2020	